

## A REVERBERATOR BASED ON ABSORBENT ALL-PASS FILTERS

Luke Dahl, Jean-Marc Jot

Creative Advanced Technology Center  
 Scotts Valley, CA, USA

[luked@atc.creative.com](mailto:luked@atc.creative.com), [jmj@atc.creative.com](mailto:jmj@atc.creative.com)

### ABSTRACT

Artificial reverberator topologies making use of all-pass filters in a feedback loop are popular, but have lacked accurate control of decay time and energy level. This paper reviews a general theory of artificial reverberators based on Unitary-Feedback Delay Networks (UFDN), which allow accurate control of the decay time at multiple frequencies in such topologies.

We describe the design of an efficient reverberator making use of chains of elementary filters, called “absorbent all-pass filters”, in a feedback loop. We show how, in this particular topology, the late reverberant energy level can be controlled independently of the other control parameters. This reverberator uses the I3DL2 control parameters, which have been designed as a standard interface for controlling reverberators in interactive 3D audio.

### 1. INTRODUCTION

There have been several reports of artificial reverberation processors made up of arrangements of all-pass filters inserted in a feedback loop [1–4]. Such reverberator topologies are attractive due to the efficient generation of echoes and theoretically colorless frequency response of all-pass filters. Furthermore, they provide a simple method for adjusting the echo density build-up in the reverberation response (as will be described later in this paper). However, these reverberators have lacked mathematically accurate means of controlling decay time characteristics, and have had to rely instead on empirical or inaccurate methods.

Accurate control of decay time has been demonstrated in a class of reverberator topologies, often referred to as “Feedback Delay Networks” (FDN), whose “lossless prototype” can be represented as a parallel bank of delay lines interconnected via a unitary (i.e. energy-preserving) feedback matrix, as in Figure 1 [4–7]. Smith and Rocchesso described a more general class of reverberation networks obtained by connecting bi-directional wave guides, which they called Digital Waveguide Networks (DWN) [7, 8].

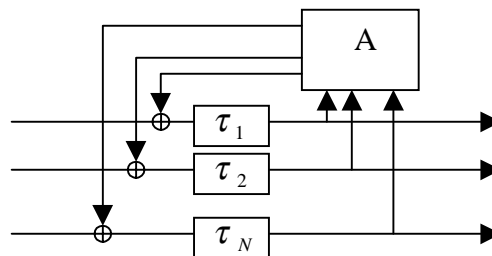

Figure 1. ‘Feedback Delay Network’ (FDN) topology

Reverberator networks that incorporate cascaded all-pass filters in the feedback loop generally do not belong to the FDN class or the DWN class. Nonetheless, they belong to a general class of reverberation prototype networks that we will call “Unitary-Feedback Delay Networks” (UFDN). This class of reverberators was initially introduced as “looped unitary systems” in [6], where it is shown that for all such systems, the decay time can be controlled accurately through attenuating and filtering all delay lines in the system, according to a prescribed frequency-dependent attenuation per sample, as in a FDN or a DWN.

As an illustration, we describe a reverberator whose late reverberation response is generated by a feedback loop containing chains of all-pass filters that are modified to have an attenuation and low-pass filter associated with each delay unit. We call these filters “absorbent all-pass filters.” This modification enables accurate control of decay time at low and high frequencies. We show how to normalize the output energy level of the reverberator, so that it can be adjusted independently of the controllable echo and modal densities.

A set of control parameters which covers the perceptually salient characteristics of typical reverberation responses has been standardized by the Interactive Audio Special Interest Group, or IA-SIG [9], for use in interactive 3D audio. The Absorbent All-Pass Reverberator uses this interface, and the implementation of these parameters is discussed.

## 2. UNITARY-FEEDBACK REVERBERATORS

Schroeder proposed an artificial reverberator consisting of a bank of parallel comb filters in series with a number of all-pass filters [10]. In this topology, the decay time is controlled using the comb filter loop gains. The all-pass filters are used to increase echo density, but there is no build up of echo density because they are out of the main feedback loop.

Gardner and Datorro [1, 2] described a reverberator topology (attributed to Griesinger) consisting of a chain of all-pass filters and delays whose output is fed back into the input. The decay time is controlled by inserting an attenuation in the chain, and the high-frequency decay time is controlled similarly by inserting low-pass filters. The presence of the all-pass filters inside the feedback loop creates a build-up of echo density over time as in real room responses. However, no method is described for explicit control of decay time or reverberation level. An advantage of this topology is that it allows control of the echo density of the reverberation (often called “diffusion”) by adjusting the feedback coefficients of the all-pass filters.

Väänänen et al. [3] modify a Feedback Delay Network similar to the network of Figure 1 by cascading with each of the delay lines an all-pass filter having a short delay. The frequency-dependent decay time is controlled exclusively by attenuations and filters associated with the ‘main’ delay lines. The addition of the all-pass filters provides a desirable increase in echo density, but also modifies the decay characteristics, making the control of decay time inaccurate.

### 2.1. Unitary-Feedback Delay Networks (UFDN)

In this section, we define UFDNs and establish the following fundamental property, demonstrated in [6], which makes them useful for designing digital reverberators:

- (a) The poles of a UFDN are all of unit magnitude, which implies that a UFDN is a valid “lossless prototype” reverberator (i. e. a reverberator with infinite decay time).

The notion of *Unitary Network* (UN) was introduced in [11] as the multi-channel equivalent of the all-pass filter. A  $N$ -input,  $N$ -output linear time invariant system is a Unitary Network if, for any  $N$ -channel input signal, the  $N$ -channel output has the same energy as the input. This is equivalent to requiring that the  $N$ -by- $N$  matrix transfer function  $\mathbf{U}(z)$  of the network be unitary for any  $z$  on the unit circle:  $|z| = 1 \Rightarrow \mathbf{U}(z)^T \mathbf{U}(z) = \mathbf{I}$ , the identity matrix. We define a *Unitary-Feedback Delay Network* (UFDN) as any network that is equivalent to a Unitary Network whose outputs have been fed back individually into its inputs.

Following the generalization introduced in [7], one can adopt a generalized definition of the energy of a multi-channel signal (replacing the  $L_2$  norm with the elliptic norm induced by a Hermitian positive-definite matrix  $\mathbf{\Gamma}$ , with  $\|x\|^2 = x^* \mathbf{\Gamma} x$ ), leading

to the notion of *Lossless Network*. For a Lossless Network, the matrix transfer function verifies  $\mathbf{U}(z)^* \mathbf{\Gamma} \mathbf{U}(z) = \mathbf{I}$  for any  $z$  on the unit circle. It can be verified that property (a) also applies to “Lossless-Feedback Delay Networks” even though the practical applications considered in this paper are limited to unitary networks and matrices (for which  $\mathbf{\Gamma} = \mathbf{I}$ ).

The class of UFDNs includes all FDNs, as illustrated in Figure 1 (because the cascade association of a unitary matrix and a parallel bank of delay units makes a Unitary Network). A  $N$ -dimensional UN can be built by cascading several  $N$ -dimensional UNs or by associating in parallel a  $L$ -dimensional UN and a  $M$ -dimensional UN such that  $L + M = N$ . As a result, an infinite variety of UFDN topologies can be built by arrangements of the following basic elements: delay units, all-pass filters and unitary mixing matrices (i.e. matrices verifying  $\mathbf{U}^T \mathbf{U} = \mathbf{I}$ ). A simple example is shown in Figure 2.

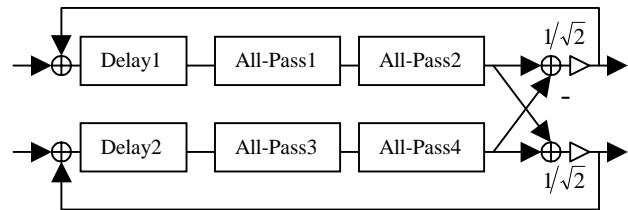

Figure 2: Example UFDN built by cascading delays, all-pass filters, and a unitary matrix in a feedback loop.

Considering a UFDN whose feedback-loop matrix transfer function is denoted  $\mathbf{U}(z)$ , the demonstration of property (a) in [6] follows the steps below:

- (a.1) The complex number  $z_0$  is a pole of the UFDN if and only if one of the eigenfunctions  $\lambda_l(z)$ ,  $l = 1..N$ , of the matrix transfer function  $\mathbf{U}(z)$  verifies  $\lambda_l(z_0) = 1$  (or, equivalently, one of the eigenvalues of the matrix  $\mathbf{U}(z_0)$  is equal to 1). This results from the fact that the system poles are the solutions of the characteristic equation  $\det[\mathbf{I} - \mathbf{U}(z)] = 0$  and that  $\mathbf{U}(z)$  is similar to a triangular matrix having the eigenfunctions  $\lambda_l(z)$  on its diagonal.
- (a.2) Because  $\mathbf{U}(z)$  is unitary for any  $z$  on the unit circle, each of the eigenfunctions  $\lambda_l(z)$  must be an all-pass transfer function, i. e.  $|z| = 1 \Rightarrow |\lambda_l(z)| = 1$ . This is because the eigenvalues of a unitary matrix have unit magnitude.
- (a.3) Requiring that the Unitary Network  $\mathbf{U}(z)$  be stable implies that each of the eigenfunctions  $\lambda_l(z)$  must be stable (analytical outside of the unit circle). By application of the Maximum Theorem [12],  $|\lambda_l(z)|$  cannot be larger than 1 if  $|z| > 1$ . Therefore a solution of (a.1) cannot be strictly outside of the unit circle.

- (a.4) Assuming that each of the all-pass eigenfunctions  $\lambda_i(z)$  is a rational transfer function (which is not restrictive), the stability of  $\lambda_i(z)$  implies that its zeros must be outside of the unit circle. Therefore  $1/\lambda_i(z)$  is analytical *inside* of the unit circle. By application of the Maximum Theorem,  $|1/\lambda_i(z)|$  cannot be larger than 1 if  $|z| < 1$ , which implies that a solution of (a.1) cannot be strictly inside of the unit circle and concludes the demonstration of property (a).

### 2.2. Explicit Control of the Decay Time

In this section, we establish a second property, which provides explicit and accurate control of the decay time of a digital reverberator by inserting attenuation in its “lossless prototype” [6]:

- (b) Applying with each delay line an attenuation whose logarithm is proportional to the delay length has the effect of multiplying the system’s impulse response by an exponentially decaying envelope.

The proof of property (b), based on [6], follows the steps below:

- (b.1) Associating with each delay unit (of length  $m_i$  expressed in samples) an attenuation  $\alpha^{m_i}$  has the effect of replacing  $z$  by  $z/\alpha$  in the system transfer function and in its characteristic equation  $\det[\mathbf{I} - \mathbf{U}(z)] = 0$ , therefore multiplying all the system poles by  $\alpha$ .
- (b.2) Considering an input signal  $x(n)$  into the UFDN and an output signal  $y(n)$ , the transfer function  $H(z)$  and the impulse response  $h(n)$  can be decomposed as follows:

$$H(z) = \sum_k \frac{r_k}{1 - z_k z^{-1}} \Rightarrow h(n) = \Omega(n) \cdot \sum_k \text{Re}(r_k z_k^n) \quad (1)$$

where  $\Omega(n)$  denotes the Heaviside step function and the complex numbers  $z_k$  are the poles of the UFDN. When  $H(z)$  becomes  $H'(z) = H(z/\alpha)$ , the impulse response is therefore multiplied by a decaying exponential envelope:

$$H'(z) = H(z/\alpha) = \sum_k \frac{r_k}{1 - \alpha \cdot z_k z^{-1}} \Rightarrow h'(n) = \alpha^n h(n) \quad (2)$$

Therefore the decay time of a UFDN can be precisely controlled by inserting an attenuation with each delay line. The decay time can be made frequency-dependent by inserting with each delay line in the UFDN a filter  $G_i(z)$  whose gain at any frequency  $\omega$  is dependent on the delay length  $\tau_i$  and the desired decay time  $Tr(\omega)$  at that frequency [5, 6]:

$$20 \log_{10} |G_i(e^{j\omega})| = -60 \tau_i / Tr(\omega) \quad (3)$$

### 2.3. The Absorbent All-Pass Filter

As a result of property (a) above, a valid method for building reverberators is based on modifying a FDN by cascading, in each branch, one or more all-pass filters with the delay unit, as illustrated in Figure 2. Examples of this approach have been described independently in [2] and [3]. We note that explicit control of the reverberation decay time by applying property (b) implies that not only the ‘main’ delay units, but also every additional delay unit in each of the all-pass filters must have a specified attenuation depending on the decay time [6].

We therefore obtain a structure similar to an all-pass filter, but with an attenuation and a filter (typically low-pass) associated with the delay unit. This elementary structure, which we call an “absorbent all-pass filter”, is shown in Figure 3. We note that the absorbent all-pass filter is actually no longer all-pass when the decay time of the reverberation is finite.

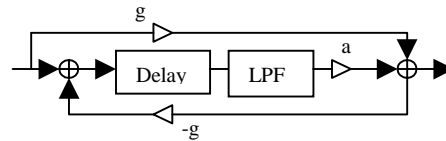

Figure 3. Absorbent All-Pass Filter

## 3. AN ABSORBENT ALL-PASS REVERBERATOR

As an illustration, we present a reverberator whose late response is generated by two chains of six absorbent all-pass filters and one delay line, each of which are fed back through an energy preserving matrix  $\mathbf{M}$  as shown in Figure 4. Two independent output signals are obtained by tapping the chains after each absorbent all-pass filter. The absorbent all-pass delay lengths are chosen to be mutually prime, and are arranged in each chain in order of increasing length in. The decay time is controlled by adjusting the attenuation and low-pass filter in each absorbent all-pass and after each delay line according to Equation (3). The modal density can be modified by scaling the amount of delay in the absorbent all-pass filters, and the echo density (or “diffusion”) can be modified by changing the all-pass coefficient ( $g$  in Figure 3) of the absorbent all-pass filters.

The complete reverberator is shown in Figure 5. The inputs are low-pass filtered before being delayed and passed to the early reflection and late reverberation blocks. The early reflections are created by tapping the input delays and passing the summed signals through normal all-pass filters. The delay values of the early reflection taps and the late reverberation feeds are functions of the Reflections Delay and Reverb Delay parameters, as described in Section 4. Figure 6 shows the impulse response for one output of this reverberator when the Decay Time is set to 2 seconds, the Reverb Delay is 50 milliseconds, and the Reflections Delay is 30 milliseconds.

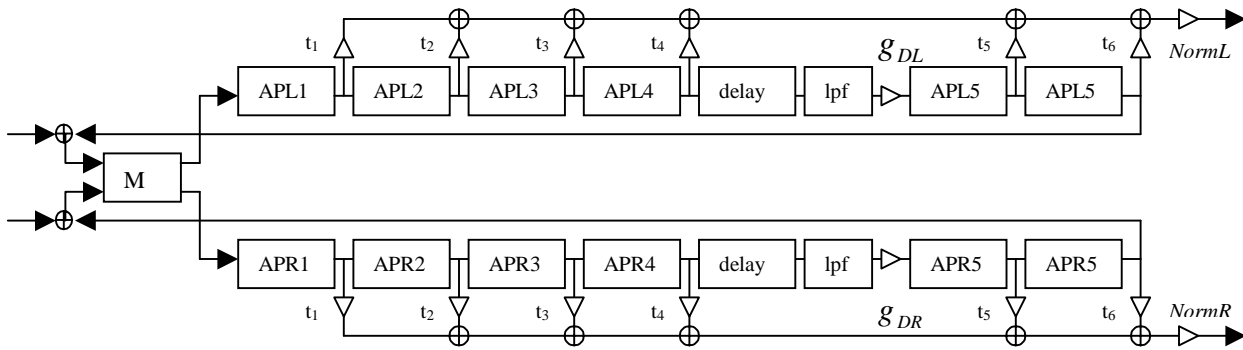

Figure 4. Late Reverberation Network

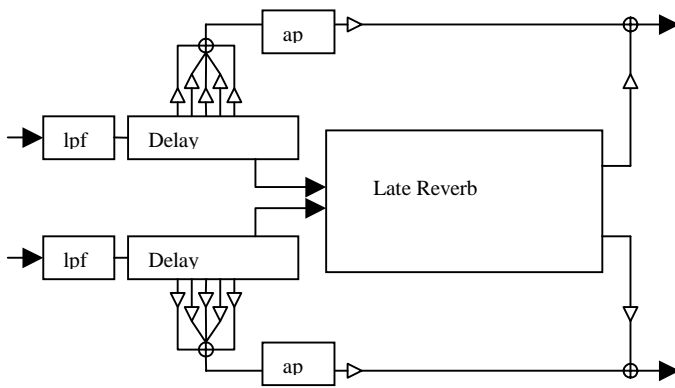

Figure 5. Complete Reverberator

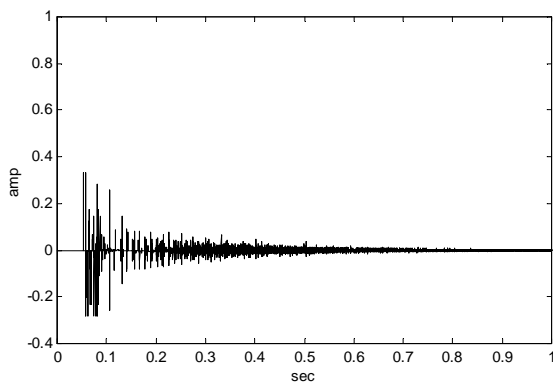

Figure 6. Absorbent All-Pass Reverberator Impulse Response

### 3.1. Energy Normalization

The intensity level of the late reverberation response can be controlled independently of the other parameter settings by normalizing the energy gain of the late reverberation network, and adjusting the level of the normalized output. To determine the energy gain of the late reverberation network it is useful to describe the network as a feedback loop with energy gain  $A$ , and output energy gain  $B$ , as in Figure 7.

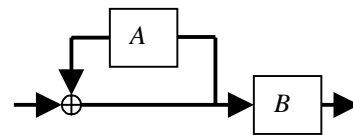

Figure 7. Energy Gain Representation of Late Reverberation Network

The energy gain is then the product of the output gain  $B$  and a geometric series of  $A$ :

$$\text{EnergyGain} = B \cdot (1 + A + A^2 + A^3 + \dots) \quad (4)$$

The system impulse response is the sum of a series of elementary impulse responses (corresponding to a different numbers of trips through the feedback loop). Equation (4) assumes that these elementary impulse responses are mutually uncorrelated signals, so that the total energy is the sum of their individual energies. We make this assumption because the impulse response of each pass through the two chains of cascaded absorbent all-pass filters should have few large interfering terms in the successive impulse response due to the mixing matrix and our use of large mutually prime delay lengths. Since, for finite decay times, the loop energy gain  $A$  is less than one, the geometric series can be simplified to  $1/(1-A)$  and the amount of normalization required is:

$$\text{Norm} = \frac{1}{\text{EnergyGain}} = \frac{1-A}{B} \quad (5)$$

To calculate the loop gain of the late reverberation network we first calculate the energy gain for each of the two chains of filters. The energy gain of each chain can be approximated as the product of the energy gains of each filter and attenuation in the chain, where energy gain of a filter is defined as the sum of its squared impulse response. We make this assumption because the use of mutually prime delay lengths ensures that the cross terms between convolved absorbent all-pass filter impulse responses will occur seldom and only late in the response where the terms are small.

The energy gain  $A$  for the entire reverberation loop is then the sum of the energy gains of the two branches:

$$A = g_{DL}^2 \cdot \prod_i c_{Li} + g_{RL}^2 \cdot \prod_i c_{Ri} \quad (6)$$

where  $c_{Li}$  is the energy gain for the  $i$ th absorbent all-pass filter in the left chain, and  $g_{DL}$  is the attenuation associated with the delay line in the left chain.

We calculate the left and right output gains  $B_L$  and  $B_R$  by assuming that the total energy gain at the output is the sum of the energy gains after each tap (see Figure 4). The energy gain after each tap is the product of the energy gain in the chain up to that tap, which is calculated as the product of filter gains, as in Equation (6), and the energy gain of the tap. For example, the output gain of the left output is:

$$B_L = t_1^2 c_{L1} + t_2^2 \cdot \prod_{i=1}^2 c_{Li} + \dots + t_6^2 g_{DL}^2 \cdot \prod_{i=1}^6 c_{Li} \quad (7)$$

The left and right outputs are normalized by multiplying by  $NormL$  and  $NormR$  where:

$$NormL = \frac{1-A}{B_L}, \quad NormR = \frac{1-A}{B_R} \quad (8)$$

The last remaining step is to calculate the energy gain for each absorbent all-pass filter, which we defined as the sum of the squared impulse response samples. We calculate the energy gain at low frequencies by ignoring the effect of the low-pass filter in the absorbent all-pass filter.

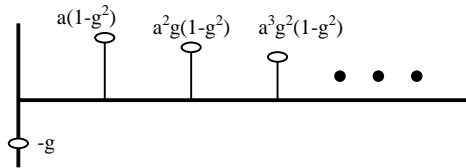

Figure 8. Impulse Response of Absorbent All-Pass Filter

By examining the impulse response of an absorbent all-pass filter (with low-pass filtering disabled) (Figure 8) it can be easily shown that the energy gain is a function of the all-pass coefficient  $g$  and the absorbent gain  $a$  (shown in Figure 3):

$$c_{Li} = g^2 + (1-g^2) \frac{a_{Li}^2}{1-a_{Li}^2g^2} \quad (9)$$

#### 4. CONTROL PARAMETERS

The control parameters of the Absorbent All-pass Reverberator have been chosen to comply with the Level 2.0 Interactive 3D Audio Rendering Guideline (I3DL2) of the 3D Working group of the Interactive Audio Special Interest Group [9]. This set of parameters was designed in an effort to standardize a basic reverberation control interface across the interactive 3D Audio industry.

The I3DL2 interface is based on a model of reverberation response in which the impulse response is divided temporally into three sections, the Direct path, the Early Reflections, and the late Reverb (see Figure 9.)

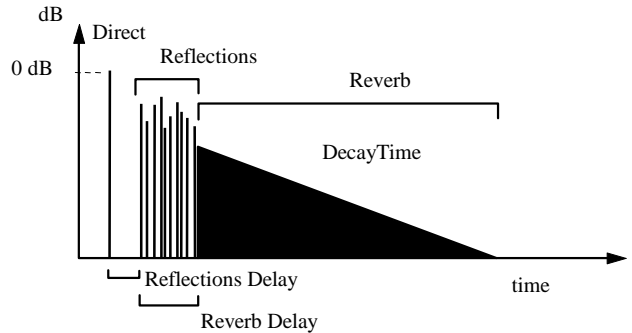

Figure 9. Reverberation Response Model

The parameters and their implementation in this reverberator are as follows:

- **Room Level** adjusts the intensity level of the reverberator's response.
- **Room High Frequency Level** adjusts the attenuation at high frequencies relative to the intensity at low frequencies by adjusting low-pass filters at the input to the reverberator (see Figure 5).
- **Decay Time** controls the time it takes the late reverb response at low frequencies to decay by adjusting the attenuations in each absorbent all-pass and associated with each delay in the late reverberation network, according to Equation (3).

- **Decay High Frequency Ratio** sets the ratio of the decay time at high frequencies to the decay time at low frequencies. This is done by adjusting the coefficients of the low-pass filters in each absorbent all-pass filter and associated with each delay in the late reverberation network, according to Equation (3).
- **Reflections Level** controls the intensity level of the early reflections.
- **Reflections Delay** adjusts the delay time between the direct sound and the first early reflection by moving the early reflection taps.
- **Reverb Level** controls the intensity level of the late reverberation response.
- **Reverb Delay** adjusts the time between the first early reflection and the onset of the late reverberation response by moving the tap that feeds the late reverb. The early reflection taps are adjusted so that the reflections span this entire time interval.
- **Diffusion** controls the percentage amount of echo density in the late reverberation response by adjusting the feedback coefficient  $g$  of each absorbent all-pass filter (Figure 3). The lowest echo density is obtained for  $g = 0$ , while the highest echo density is obtained for  $g \approx 0.6$ .
- **Density** controls the modal density in the late reverberation response by scaling the length of the delay lines in the absorbent all-pass filters.
- **High Frequency Reference** sets the frequency at which the Room High Frequency Level and Decay High Frequency Ratio parameters are controlled.

## 5. CONCLUSION

We have introduced a general class of artificial reverberator topologies, called Unitary-Feedback Delay Networks, and shown that, for any reverberator of this class, it is possible to control the decay time characteristics accurately by associating an attenuation with each delay in the system. UFDNs include the reverberator topologies obtained by inserting all-pass filters in the branches of a Feedback Delay Network, which have lacked an accurate method of controlling the reverberation's level and decay time. We have described a reverberator based on this topology, which has accurate and independent decay time and intensity level controls, also independent from its echo density and modal density controls.

## 6. ACKNOWLEDGEMENTS

Some of the ideas described in this paper are covered by a patent application. The use of the Maximum Theorem in the

demonstration of property (a) in section 2.1 was suggested by Jean Laroche.

## 7. REFERENCES

- [1] Gardner, W.G., "A Realtime Multichannel Room Simulator", *J. Acoust. Soc. Am.*, 92(4(A)):2395. <http://sound.media.mit.edu/papers.html>, 1992.
- [2] Dattorro, J., "Effect Design Part I: Reverberator and Other Filters", *J. Audio Eng. Soc.*, 45(9):660-684, 1997.
- [3] Väänänen, R., Välimäki, V., Huopaneemi, J., and Karjalainen, M., "Efficient and Parametric Reverberator for Room Acoustics Modeling", *Proceedings International Computer Music Conference*, pp 200-203, 1997.
- [4] Gardner, W.G. "Reverberation Algorithms", *Applications of Digital Signal Processing to Audio and Acoustics*, pp 85-131, Kluwer Academic Publishers, Boston, 1997.
- [5] Jot, J.M., "Digital Delay Networks for Designing Artificial Reverberators", *AES 90<sup>th</sup> Convention Preprints*, 1991.
- [6] Jot, J.M., "Study and Implementation of a Sound Spatializer Through Physical and Perceptual Models", PhD Thesis, Telecom Paris, 1992.
- [7] Rocchesso, D., Smith, J.O., "Circulant and Elliptic Feedback Delay Networks for Artificial Reverberation", *IEEE Trans. Speech and Audio Proc.*, 5(1):51-63, 1997.
- [8] Smith, J.O., "A New Approach to Digital Reverberation Using Closed Waveguide Networks", *Proceedings International Computer Music Conference*, pp 47-53, 1985.
- [9] IA-SIG, "Interactive 3D Audio Rendering Guideline Level 2", [www.iasig.org](http://www.iasig.org), 1999.
- [10] Schroeder, M.R., "Natural Sounding Artificial Reverberation", *J. Audio Eng. Soc.*, 10(3):219-223, 1962.
- [11] Gerzon, M.A., "Unitary (Energy Preserving) Multichannel Networks with Feedback". *Electronics Letters*, 12(11):278-279, 1976.
- [12] Papoulis, A., *The Fourier Integral and its Application*, McGraw Hill, 1962. Appendix II.